



European Technical Assessment **ETA 17/0244** of 23/09/2022

I General Part

Technical Assessment Body issuing the ETA	Eurofins Expert Services Oy
Trade name of the construction product	Arras Purlin Anchors
Product family to which the construction product belongs	Three-dimensional nailing plates
Manufacturer	Arras Construction Furniture OÜ Valli tee 17 75413 Vaela küla, Kiili vald Estonia www.arrascf.eu
Manufacturing plant	Arras Construction Furniture OÜ Valli tee 17 75413 Vaela küla, Kiili vald Estonia
This European Technical Assessment contains	21 pages including 2 Annexes which form an integral part of this assessment
This European Technical Assessment is issued in accordance with regulation (EU) No 305/2011, on the basis of	EAD 130186-00-0603 for Three-dimensional nailing plates
This ETA replaces	ETA 17/0244 of 19/04/2017

Translations of this European Technical Assessment in other languages shall fully correspond to the original issued document and should be identified as such.

Communication of this European Technical Assessment, including transmission by electronic means, shall be in full excepted the confidential Annex(es) referred to above. However, partial reproduction may be made, with the written consent of the issuing Technical Assessment Body. Any partial reproduction has to be identified as such.

II Specific Part

1 Technical description of the product

Arras Purlin Anchors type 72101 Right, 72102 Left, 72103 Right, 72104 Left, 72105 Right, 72106 Left, 72107 Right, 72108 Left, 72109 Right, 72110 Left, 72111 Right and 72112 Left are one piece, non-welded, face-fixed purlin anchors to be used in timber to timber connections. The type of the connector and the typical use of the purlin anchors are shown in Figure 1. The purlin anchors are connected to the timber members by anchor nails or screws.

Arras Purlin Anchors are made from pre-galvanized steel DX51D+Z275 or S250GD+275Z according to EN 10346:2015 with minimum yield strength R_{eL} or $R_{p0.2}$ of 250 N/mm² and minimum tensile strength R_m of 330 N/mm². Dimensions and hole position of the connectors are shown in Annex 1. The purlin anchors are made from steel with tolerances according to EN 10143.



Figure 1. Types of right and left hand purlin anchors and the typical use of connectors.

2 Specification of the intended uses in accordance with the applicable EAD

2.1 Intended uses

The purlin anchors are intended for use in making connections in load bearing timber structures, as a connection between a beam and a purlin, where requirements for mechanical resistance and stability and safety in use shall fulfilled.

Two same sizes of connectors with the same number of fasteners are always used symmetrically at both sides of the purlin (see Figure 1).

The Arras Purlin Anchors are used as a purlin to beam or purlin to column connection subjected to a tension load parallel to the length direction of the connector (see Annex 2). The Purlin Anchors are not assumed to have any load-carrying capacity for lateral forces perpendicular to the length direction of the connector.

The static and kinematic behaviour of the timber members or the supports shall be as described in Annex 2. The wood members can be solid timber according to EN 14081, glued laminated timber according to EN 14081 or LVL (Laminated Veneer Lumber) according to EN 14374. The characteristic density ρ_k of the timber shall not be greater than 500 kg/m³. Timber parts are not pre-bored for the fasteners. Nails and screws shall be inserted perpendicular to the grain direction of wood. Purlin anchors shall not be fixed to the edge face of a LVL member.

The Arras Purlin Anchors shall be fixed by anchor nails or screws according to EN 14592 (see Figure 2). The diameter of the anchor nails d shall be 4,0 mm and the profiled length shall be at least 24 mm. The diameter of the smooth part of the anchor screws d shall be 4,5...5,0 mm and the inner diameter of the threaded part $d_s \geq 3,0$ mm. The length of the threaded part of the screw shall be at least $6d$.



Figure 2. Fasteners: a) anchor nail and b) anchor screw.

The design of the connections shall be in accordance with Eurocode 5. The timber members shall have a thickness which is larger than the penetration depth of fasteners into members.

The purlin anchors are intended for use for connections subject to static and quasi-static loading.

The purlin anchors are for use in timber structures subject to the dry, internal conditions defined by the service classes 1 and 2 of EN 1995-1-1.

2.2 Working life

The provisions made in this European Technical Assessment are based on an assumed intended working life of the purlin anchors of 50 years.¹

2.3 Identification

Arras Purlin Anchors are identified by product labels that are marked with "ARRAS" logo.

¹ This means that it is expected that when this working life has elapsed, the real working life may be, in normal use conditions, considerably longer without major degradation affecting the essential requirements of the works. The indications given as to the working life of a product cannot be interpreted as a guarantee given by the producer or the assessment body. They should only be regarded as a means for the specifiers to choose the appropriate criteria for products in relation to the expected, economically reasonable working life of the works.

3 Performance of the product and references to the methods used for its assessment

Table 1. Handling of basic requirements for construction works

Basic requirement and essential characteristics	Performance
BWR 1. Mechanical resistance and stability	
Joint strength	Clause 3.1
Joint stiffness	No performance assessed
Joint ductility	No performance assessed
Resistance to seismic actions	No performance assessed
Resistance to corrosion and deterioration	Clause 3.1
BWR 2. Safety in case of fire	
Reaction to fire	Clause 3.2
Resistance to fire	No performance assessed

3.1 Mechanical resistance and stability, BWR 1

3.1.1 Joint strength

Characteristic resistance values of Arras Purlin Anchors are given in Annex 2.

3.1.2 Resistance to corrosion and deterioration

Arras Purlin Anchors have been assessed as having satisfactory durability and serviceability when used in timber structures when the timber species (including timbers preserved with organic solvent, boron diffusion and related preservatives) described in Eurocode 5 (EN 1995-1-1: 2004) are used and the structures are subject to the dry, internal conditions defined by service classes 1 and 2.

3.2 Safety in case of fire, BWR 2

3.2.1 Reaction to fire

Arras Purlin Anchors are made of materials classified to have reaction to fire class A1 according to EN 13501-1.

4 Assessment and verification of constancy of performance (hereinafter AVCP) system applied, with reference to its legal base

According to the Decision 97/638/EC of the European Commission², the system of assessment and verification of constancy of performance (see Annex V to the regulation (EU) No 305/2011) is System 2+.

² Official Journal of the European Communities L 268 of 1/10/1997

5 Technical details necessary for the implementation of the AVCP system, as provided for in the applicable EAD

Technical details necessary for the implementation of the AVCP system are laid down in the control plan deposited at Eurofins Expert Services Oy prior to CE marking.

Issued in Espoo on September 23, 2022
by Eurofins Expert Services Oy

Katja Vahtikari
Manager, Certification & Inspection

Ari Kevarinmäki
Leading Expert

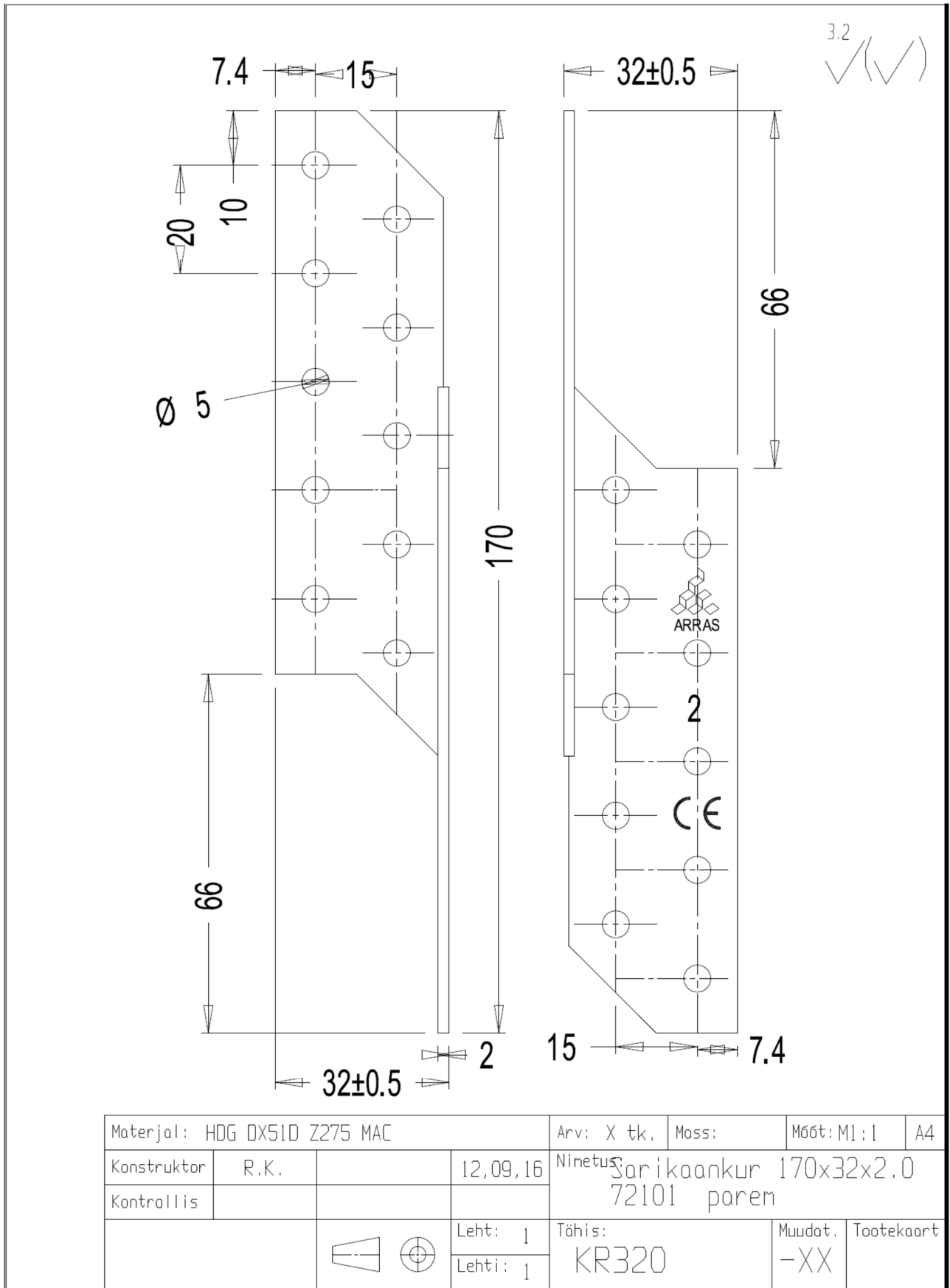

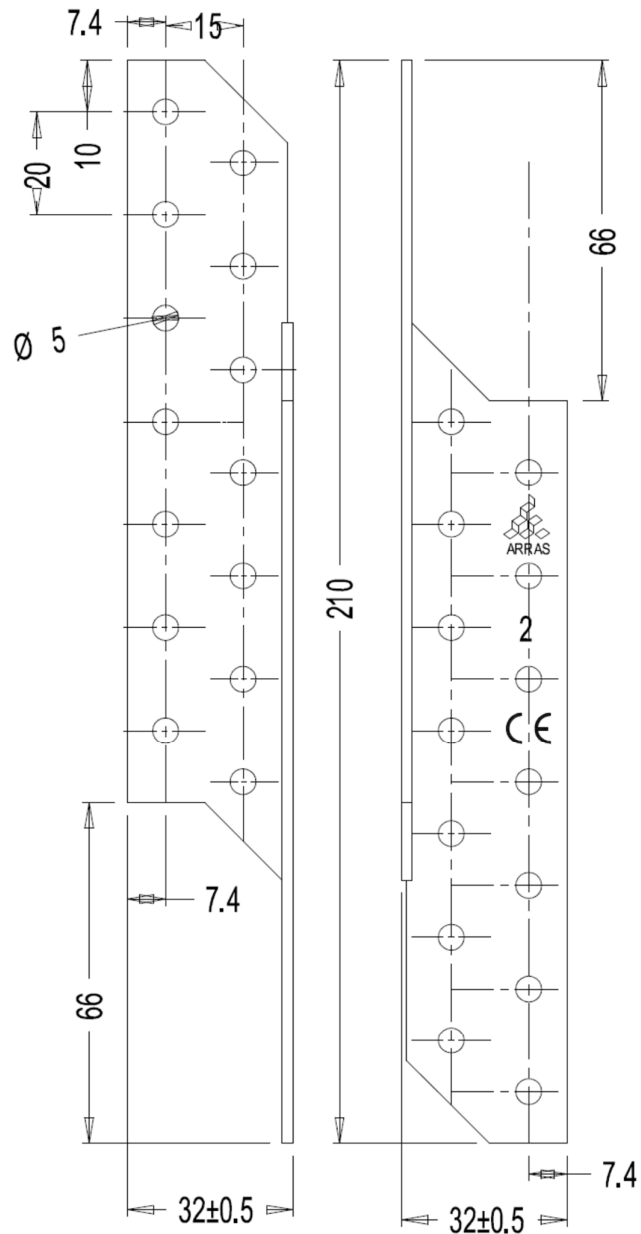

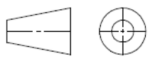
Materjal: HDG DX51D Z275 MAC				Arv: X tk.	Moss:	Mõõt: M1:1	A4
Konstruktor	R.K.		12,09,16	Ninetus: Sarikaankur 210x32x2.0 72103 parem			
Kontrollis							
			Leht: 1 Lehti: 1	Tähis: KR320		Muudat. -XX	Tootekaart

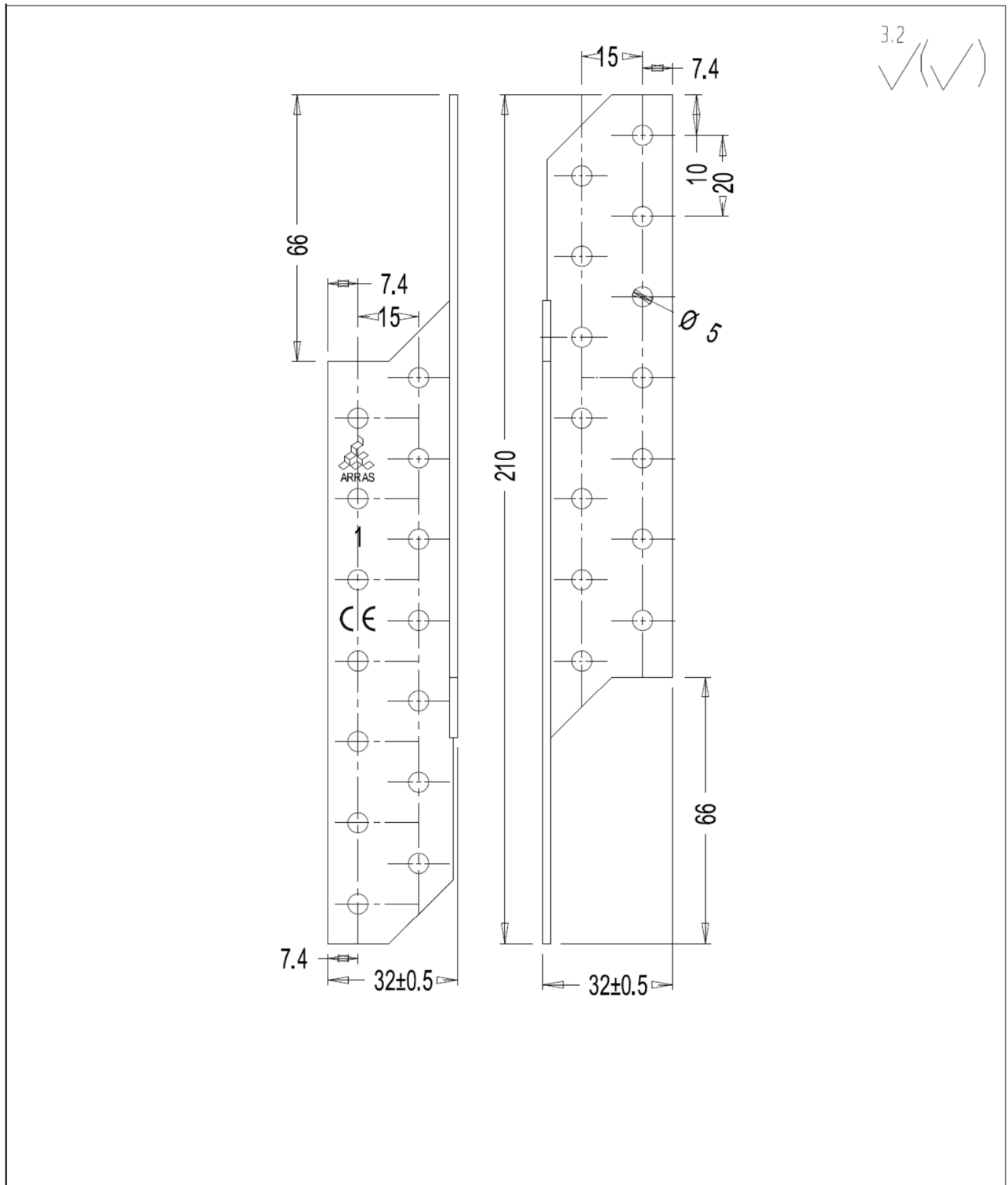

Materjal: HDG DX51D Z275 MAC.				Arv: X tk.	Moss:	Mõõt: M1;1	A4
Konstruktor	R.K.		12,09,16	Nõuetus: Sarikaankur 210x32x2.0 72104 vasak			
Kontrollis							
			Leht: 1 Lehti: 1	Tähis: KR320		Muudat. -XX	Tootekaart

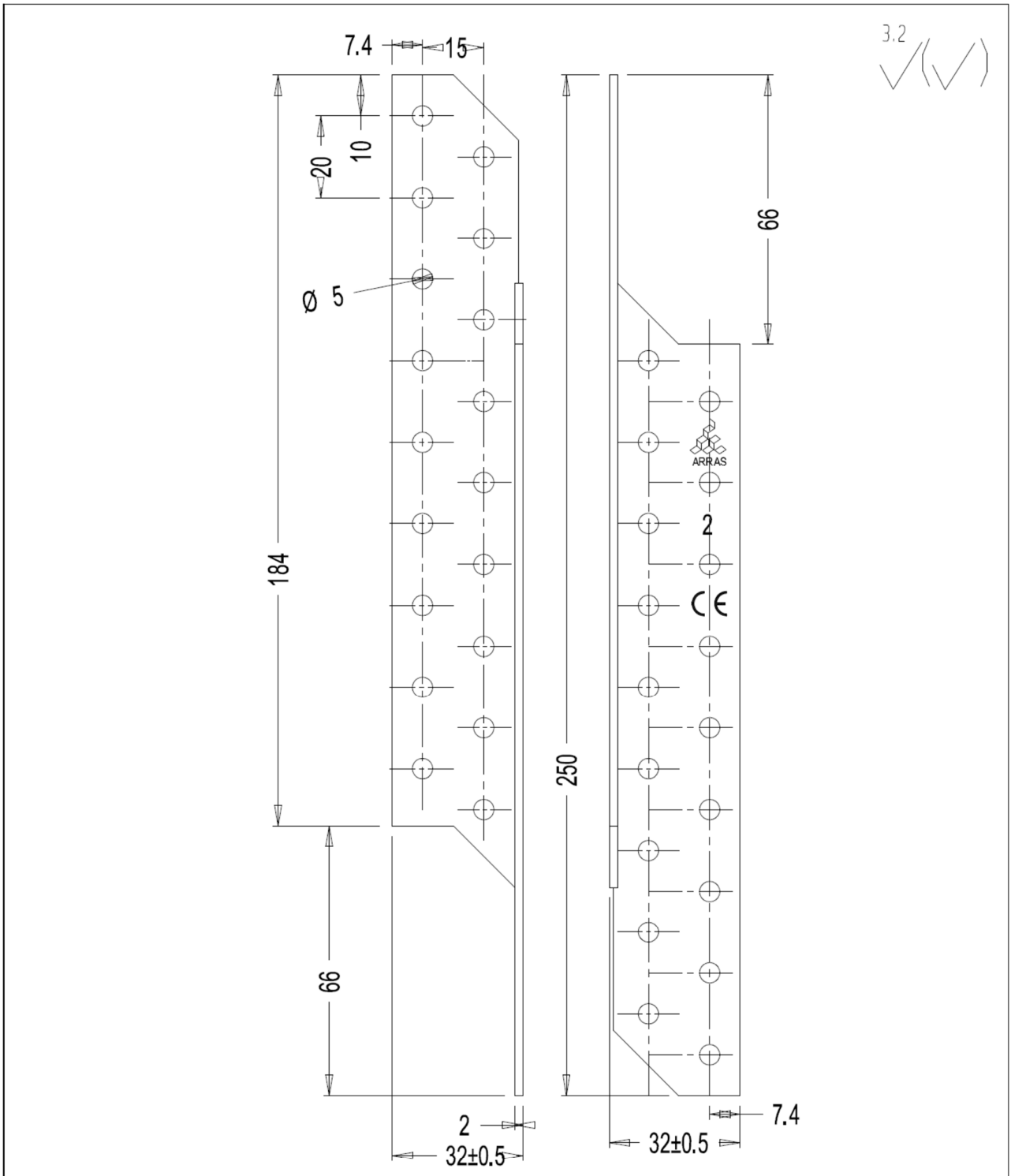

Materjal: HDG DX51D Z275 MAC			Arv: X tk.	Mass:	Mõõt: M1:1	A4
Konstruktor	R.K.	12,09,16	Ninetus Sarikaankur 250x32x2.0 72105 parem			
Kontrollis						
		Leht: 1	Tõhis: KR320		Muudat. -XX	Tootekaart
		Leht: 1				

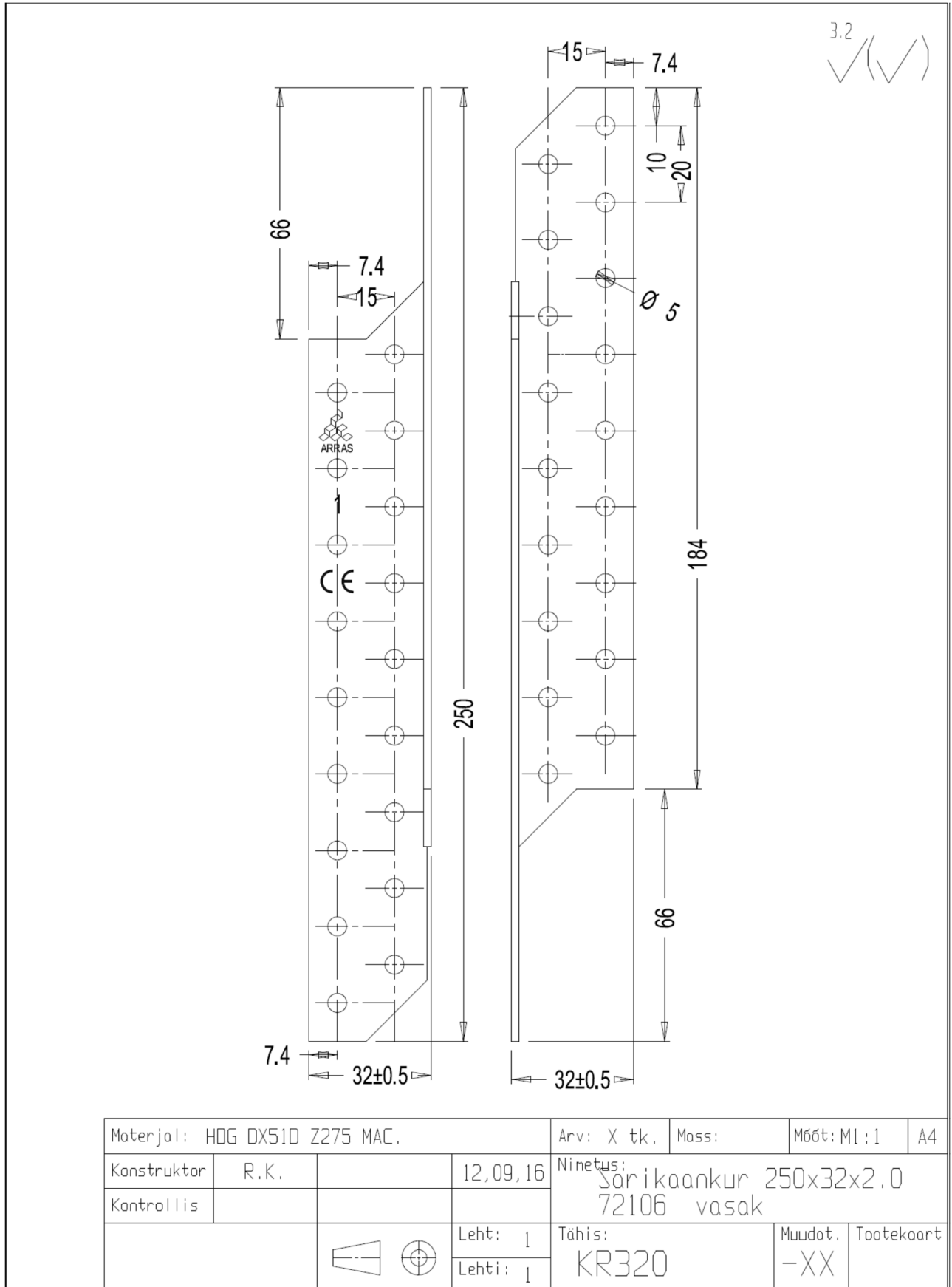

ANNEX 1: Product details and definitions

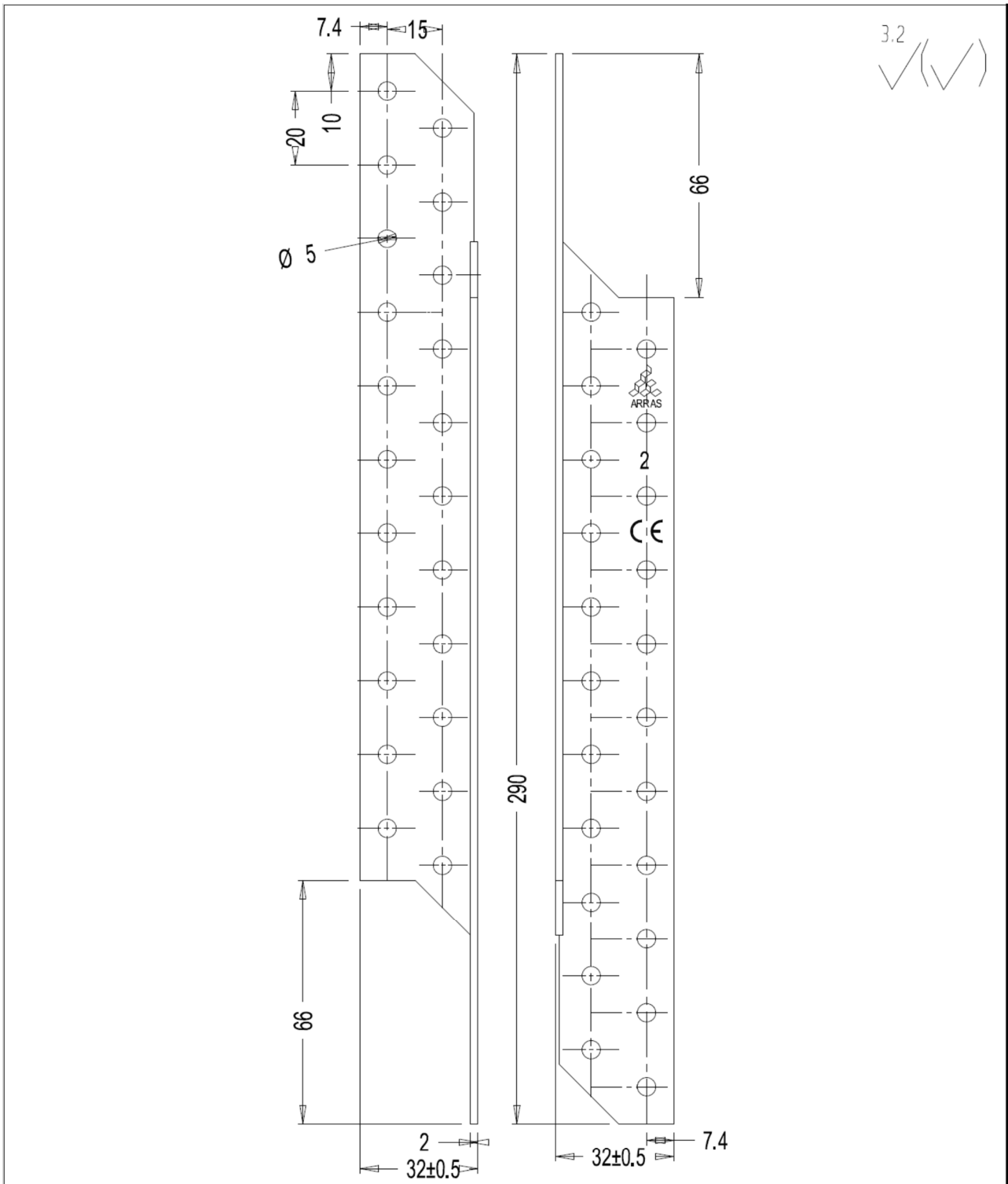

3.2

Materjal: HDG DX51D Z275 MAC				Arv: X tk.	Moss:	Mõõt: M1:1	A4
Konstruktor	R.K.		12,09,16	Nõuetus: Sarikaankur 290x32x2.0 72107 parem			
Kontrollis							
			Leht: 1 Lehti: 1	Tähis: KR320		Muudat. -XX	Tootekaart

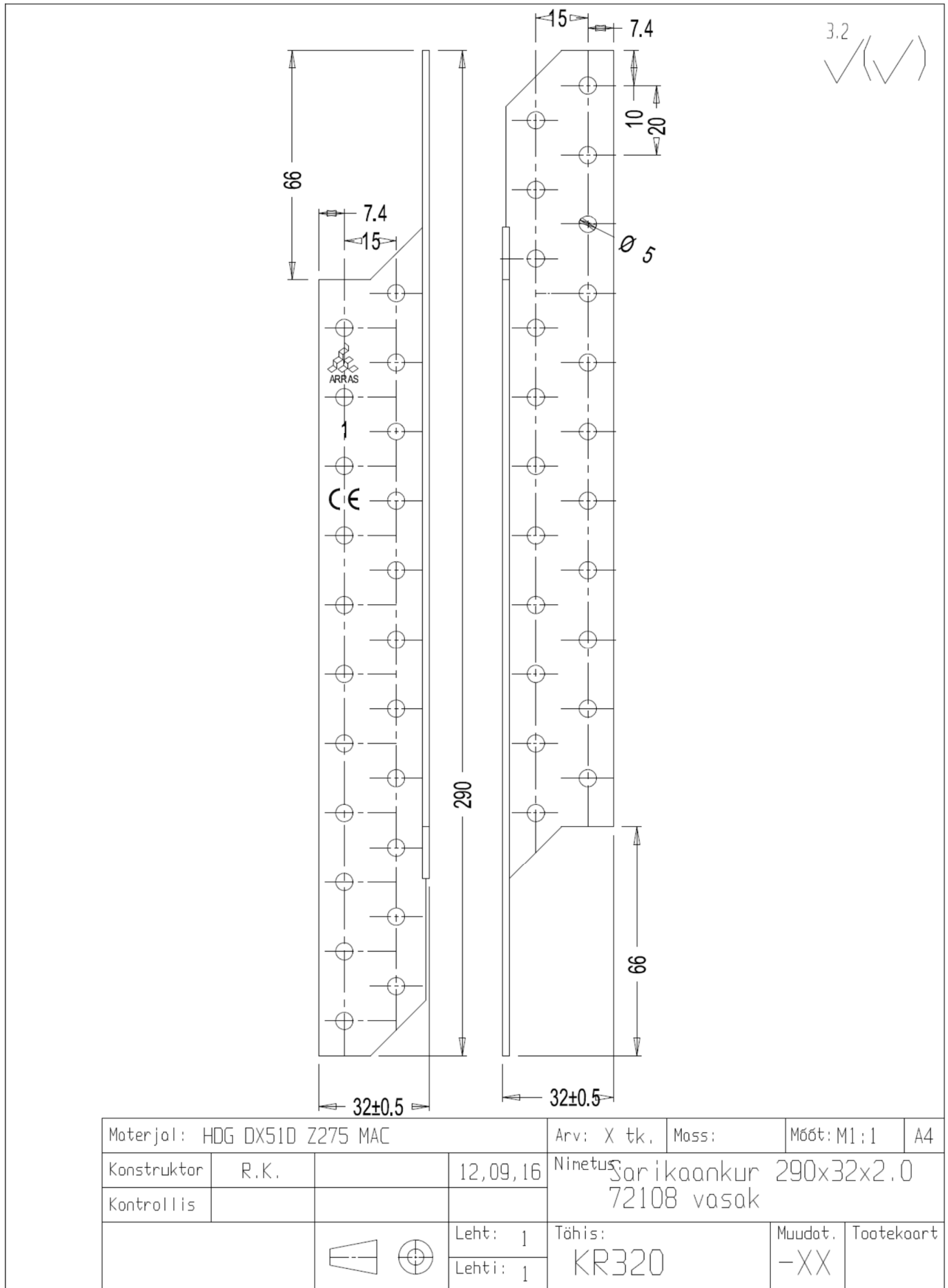

ANNEX 1: Product details and definitions

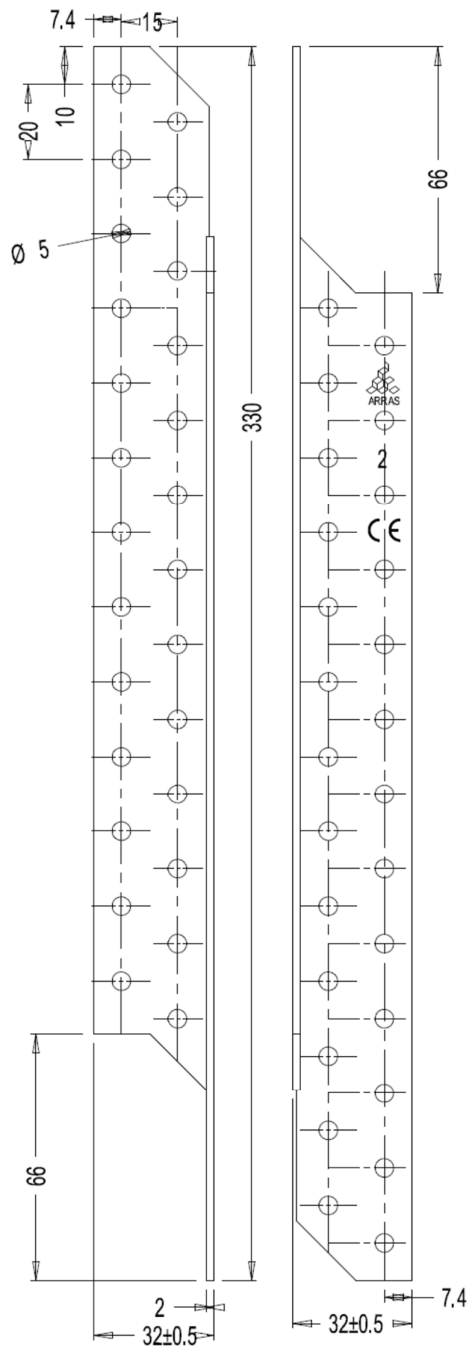

3.2

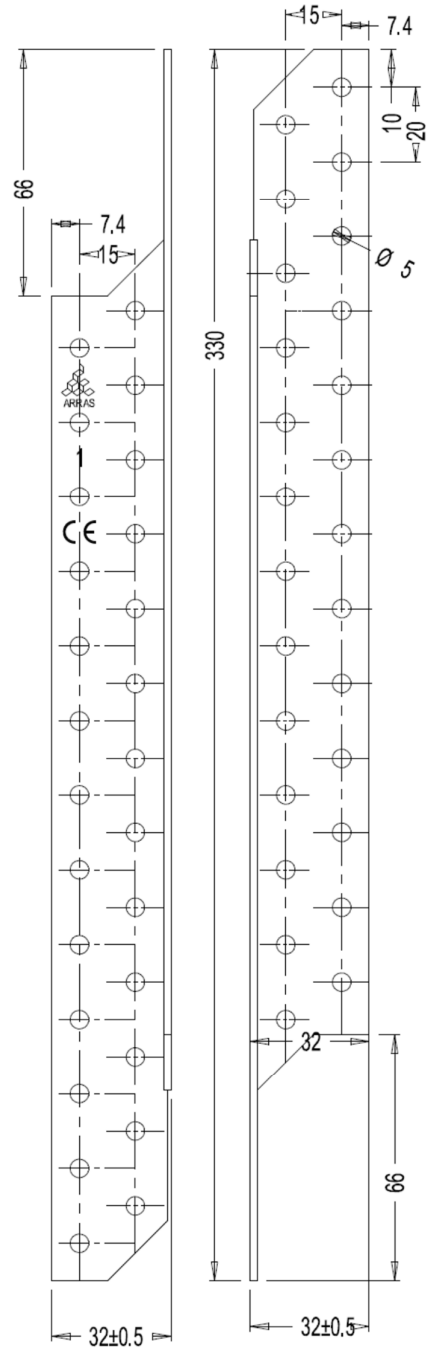

Materjal:		HDG DX51D Z275 MAC.		Arv:	X tk.	Mass:	M66t: M1:1	A4	
Konstruktor	R.K.		12,09,16	Ninetus:					
Kontrollis				Sarikaankur 330x32x2.0 parem 72109					
				Leht:	1	Tõhis:		Muudot.	Tootekoart
				Leht:	1				

3.2

Materjal: HDG DX51D Z275 MAC.		Arv: X tk.	Mass:	Mõõt: M1; l	A4
Konstruktor	R.K.	12,09,16	Ninetus: Sarikaankur 330x32x2.0 vasak 72110		
Kontrollis					
		Leht: 1	Tõhis: KR320	Muudot. -XX	Tootekaart
		Lehti: 1			

ANNEX 1: Product details and definitions

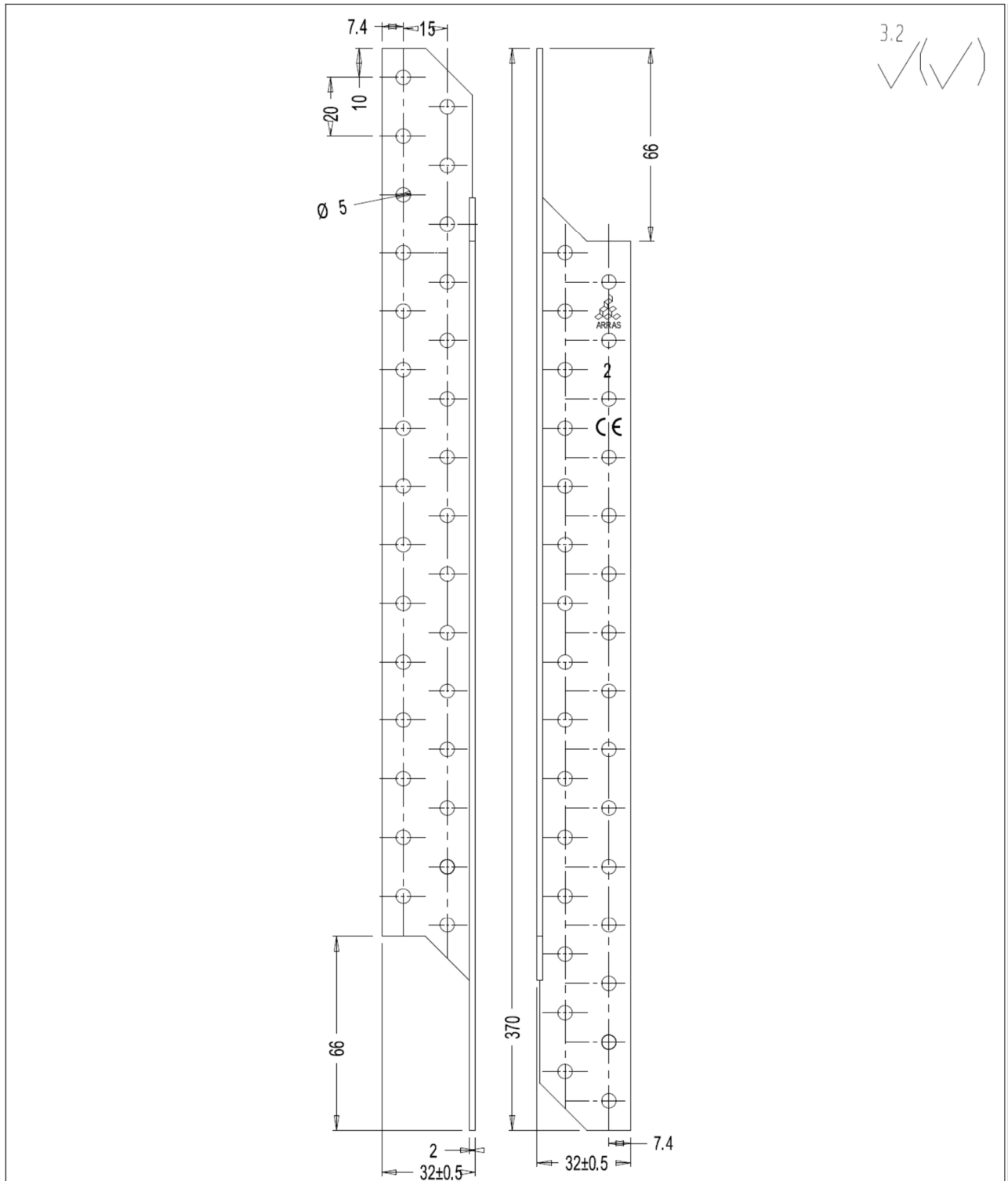

3.2

Materjal:		HDG DX51D Z275 MAC.		Arv:	X tk.	Mass:	Mõõt: M1;1	A4
Konstruktor	R.K.		12,09,16	Nõuetus:				
Kontrollis				Sarikaankur 370x32x2.0 parem 72111				
				Tähis:		Muudat.	Tootekaart	
				KR320		-XX		

ANNEX 1: Product details and definitions

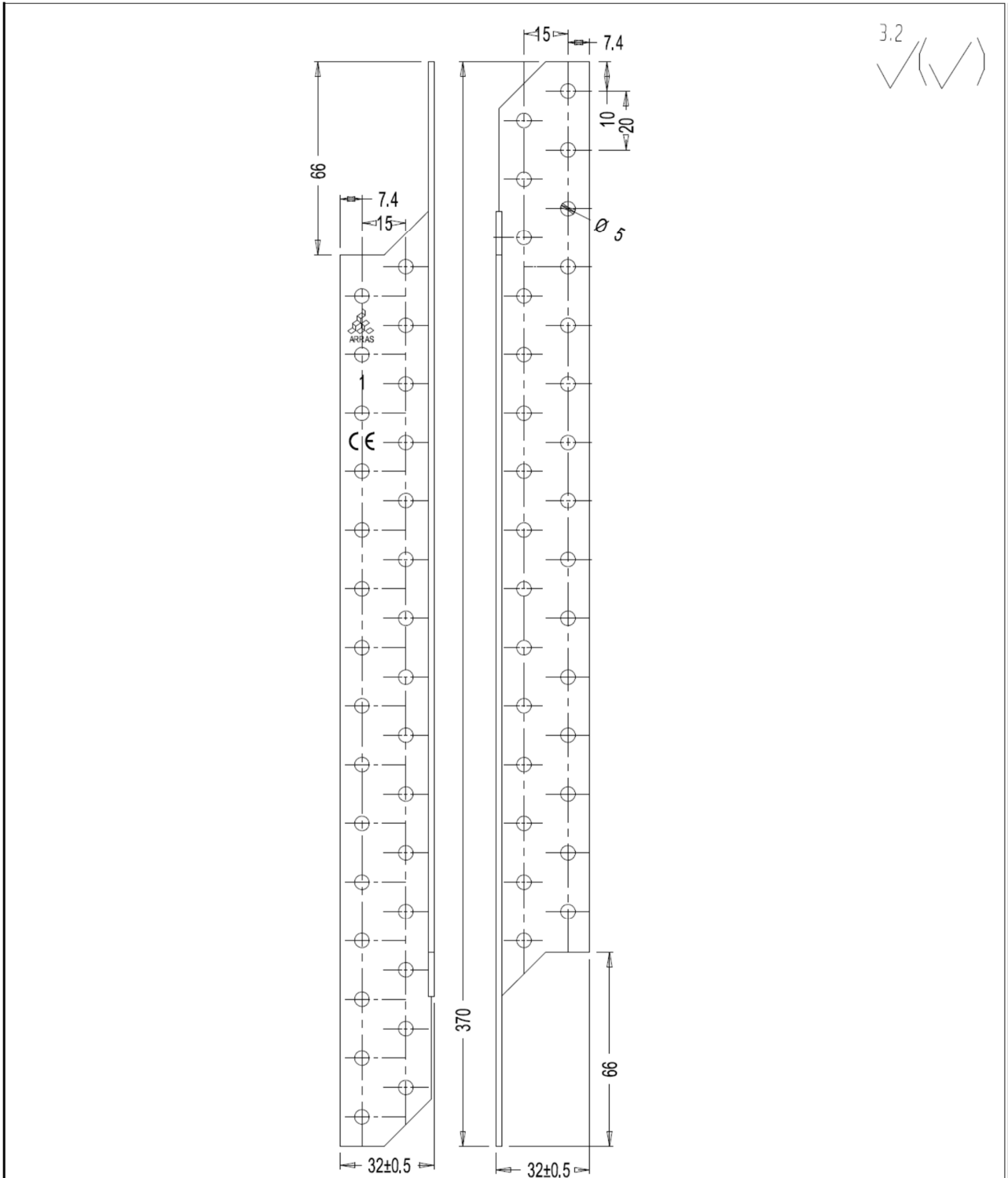

Materjal: HDG DX51D Z275 MAC.		Arv: X tk.	Mass:	Mõõt: M1:1	A4
Konstruktor	R.K.	12,09,16	Ninetus: Sarikaankur 370x32x2.0 vasak 72112		
Kontrollis					
		Leht: 1	Tõhis: KR320	Muudat. -XX	Tootekoart
		Lehti: 1			

ANNEX 2. CHARACTERISTIC LOAD-CARRYING CAPACITIES

Characteristic resistances for Arras Purlin Anchors - calculation method

Lateral load-carrying capacity of fastener

The characteristic load-carrying capacity for nails and screws in Arras Purlin Anchor connections per fastener should be taken as the minimum value found from the following expressions:

- for a thick fastener $d \geq 4$ mm:

$$F_{v,Rk} = \min \begin{cases} 0,4f_{h,k}t_1d & \text{(a)} \\ 1,15\sqrt{2M_{y,Rk}f_{h,k}d} + \frac{F_{ax,Rk}}{4} & \text{(b)} \end{cases} \quad (1)$$

- for a thin fastener $d \leq 2$ mm:

$$F_{v,Rk} = \min \begin{cases} f_{h,k}t_1d & \text{(a)} \\ f_{h,k}t_1d \left[\sqrt{2 + \frac{4M_{y,Rk}}{f_{h,k}d t_1^2}} - 1 \right] + \frac{F_{ax,Rk}}{4} & \text{(b)} \\ 2,3\sqrt{M_{y,Rk}f_{h,k}d} + \frac{F_{ax,Rk}}{4} & \text{(c)} \end{cases} \quad (2)$$

- for a fastener $2 \text{ mm} < d < 4$ mm, linear interpolation between equations (1) and (2) is used.

In equations (1) and (2) the penetration length of fastener in timber $t_1 = L - t$, when L is the length of fastener and t is the thickness of steel plate, d is the nominal diameter of nail or the effective diameter of screw = $1,1d_i$, when d_i is the inner diameter of threaded part of screw, $M_{y,k}$ is the characteristic yield moment of the fastener determined according to standards EN 14952 and EN 409, $F_{ax,k}$ is the characteristic withdrawal capacity of the fastener with a limitation of term $F_{ax,k}/4$ at maximum to 1/3 with nails and to 1/2 with screws from the load-carrying capacity $F_{v,Rk}$ and the characteristic embedding strength

$$f_{h,k} = 0,082\rho_k d^{-0,3} \quad \text{N/mm}^2 \quad (3)$$

where ρ_k is the characteristic density of timber.

The capacity according to equation (2) may be used for anchor nails of diameter 4,0 mm provided, that it has a cone head with minimum conical part length of 4 mm and the minimum cone diameter of 5,2 mm at the head of nail.

Load-carrying capacity of Purlin Anchor connection

The Purlin Anchors are used as a purlin to beam or a purlin to column connection subjected to a tension load F_d parallel to the length direction of the connector (see Figure A.2.1). The Purlin Anchors are not assumed to have any load-carrying capacity for lateral forces perpendicular to the length direction of the connector. Two same sizes of connectors with the same number of fasteners are always used symmetrically at both sides of the beam for that a pure tension force would act on the plane of the flange of the connector without any eccentricity.

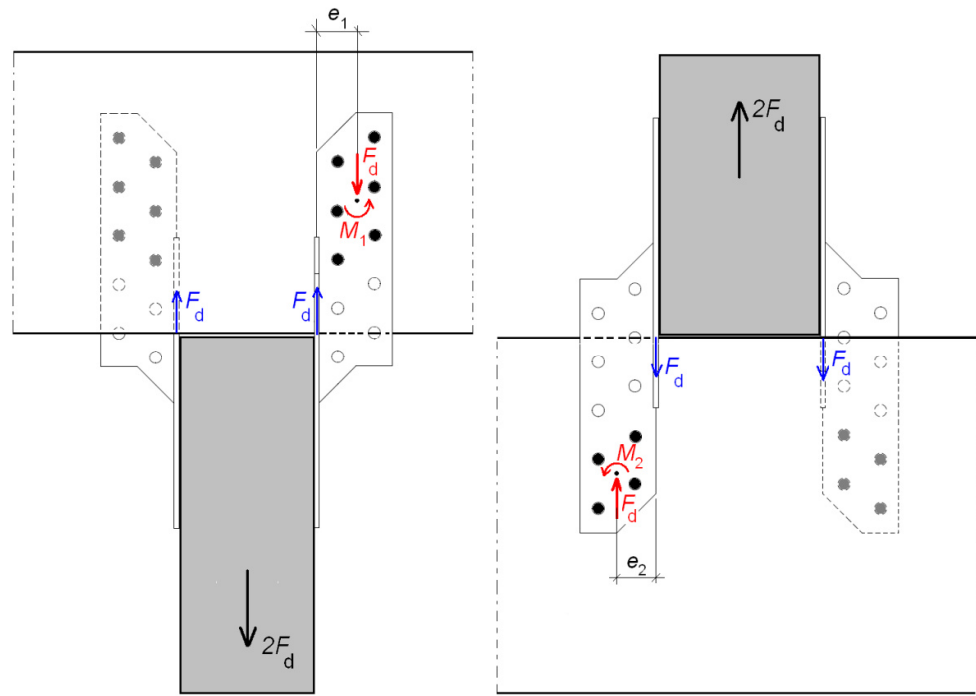

Figure A.2.1 Use of Purlin Anchors as tension connectors and the forces and moments acting in the Purlin Anchor.

The characteristic load-carrying capacity per purlin anchor should be taken as follows:

- for failure in steel:

$$F_{Rk,S} = 3,66 \text{ kN} \quad (4)$$

- for failure in nailed or screwed timber-to-steel connection:

$$F_{Rk,H} = \min \left\{ \begin{array}{l} \frac{F_{v,Rk,1}}{1 + \frac{e_1}{\sum_{i=1}^{n_1} r_{i,1}}} \\ \frac{F_{v,Rk,2}}{1 + \frac{e_2}{\sum_{i=1}^{n_2} r_{i,2}}} \end{array} \right. \quad (5)$$

where:

$F_{v,Rk,j}$ is the characteristic lateral load-carrying resistance of the fastener in the timber member of flange $j = 1$ or 2 calculated according to expressions (1) and (2);

e_j is the eccentricity of the fastener group from the line of bent edge in the flange $j = 1$ or 2 (see Figure A.2.1);

$r_{i,j}$ is the distance of fastener i from the centroid of the fastener group in flange j ;

n_j is the number of fasteners in flange $j = 1$ or 2.

Values of e_j and $\sum r_{i,j}$ for the certain number of fasteners n_1 and n_2 are presented in Table A.2.1, when the fasteners are inserted to the all holes from the ends of the connector (see Figure A.2.1).

Table A.2.1 Purlin Anchors – article numbers and nominal dimensions. Presented eccentricities e_j and moments arms $\Sigma r_{i,j}$ are valid for the given number of fasteners n_j .

Art. No.	size (mm)	e_1 (mm)	e_2 (mm)	n_1	n_2	$\Sigma r_{i,1}$ (mm)	$\Sigma r_{i,2}$ (mm)
72101 Right	170x32x2,0	16,1	16,1	6	4	103,8	51,6
72102 Left	170x32x2,0	16,1	16,1	6	4	103,8	51,6
72103 Right	210x32x2,0	16,1	16,1	8	6	175,4	103,8
72104 Left	210x32x2,0	16,1	16,1	8	6	175,4	103,8
72105 Right	250x32x2,0	16,1	16,1	10	8	266,6	175,4
72106 Left	250x32x2,0	16,1	16,1	10	8	266,6	175,4
72107 Right	290x32x2,0	16,1	16,1	12	10	377,6	266,6
72108 Left	290x32x2,0	16,1	16,1	12	10	377,6	266,6
72109 Right	330x32x2,0	16,1	16,1	14	12	508,5	377,6
72110 Left	330x32x2,0	16,1	16,1	14	12	508,5	377,6
72111 Right	370x32x2,0	16,1	16,1	16	14	659,2	508,5
72112 Left	370x32x2,0	16,1	16,1	16	14	659,2	508,5

Design condition

The following design condition shall be satisfied:

$$F_d \leq \min \left\{ \begin{array}{l} k_{\text{mod}} \cdot F_{\text{Rk,H}} \\ \gamma_M \\ F_{\text{Rk,S}} \\ \gamma_{\text{M0}} \end{array} \right. \quad (6)$$

where

- F_d is the design tension force per connector according to Figure A.2.1;
- k_{mod} is the modification factor according to Eurocode 5 taking into account the effect of the duration of the load and moisture content for the timber member;
- γ_M is the partial safety factor for the resistance of connections according to the actual National annex of EN 1995-1-1;
- $F_{\text{Rk,H}}$ is the characteristic load-carrying capacity of the connector according to the expression (5);
- γ_{M0} is the partial safety factor for the resistance of steel cross-section according to the actual National annex of EN 1993-1-1;
- $F_{\text{Rk,S}}$ is the characteristic load-carrying capacity of connector according to the expression (4).

Structural requirements

The following provisions apply:

- The nailing pattern may be determined by case by case. However, at least two fasteners shall be used in both flanges of the connector.
- All minimum spacings and edge/end distances in accordance with Eurocode 5 shall be complied with.
- The splitting resistance of the timber members shall be verified according to Eurocode 5.

- The cross section of the connected timber members shall have a plane surface without wane against the purling anchor.
- There are no specific requirements relating to preparation of the timber members.
- In service class 2, the nails and screws shall have an electroplated zinc coating according to EN ISO 2081 at least of type and thickness Fe/Zn 12 c, or they shall be hot dip zinc coated according to EN ISO 1461, thickness at least 39 µm.
- The purlin anchors shall not be used without adequate protection for connections where resistance to fire is required.